

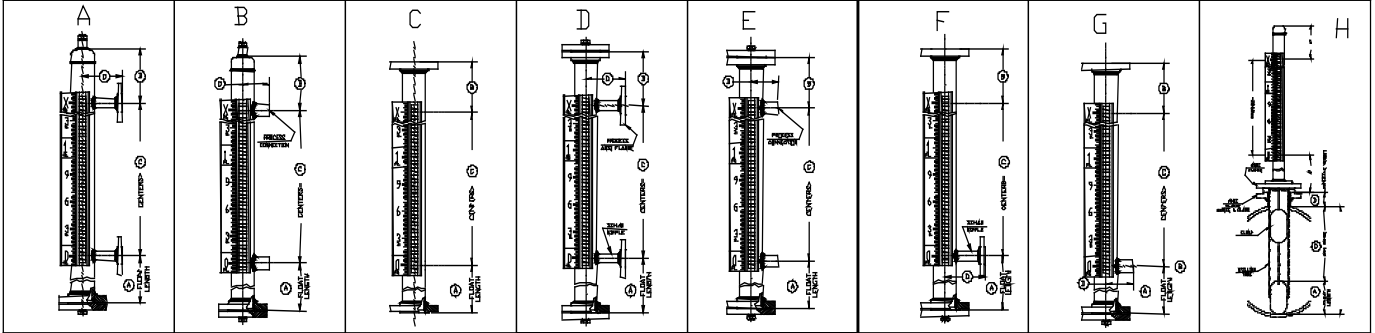

Process Level Technology, Ltd.

Mag-Gage® Application Sheet

Date: _____



<p>Style: _____</p> <p>Chamber Material: _____</p> <p>Process Connections: Material _____ Size _____ Rating _____ Type _____ Center/Center _____ Vent _____ Connection _____ Drain Connection _____</p> <p>Process Conditions: Process _____ Oper. Pressure _____ Max. Pressure _____ Oper. Temperature _____ Max. Temperature _____ Specific Gravity _____ Interface ___yes___no</p>	<p>Indicator:</p> <p><input type="checkbox"/> Wide Flag®</p> <p><input type="checkbox"/> Stainless Wide Flag®</p> <p><input type="checkbox"/> Wide Tracker®</p> <p><input type="checkbox"/> Stainless Wide Tracker®</p> <p>Scale:</p> <p><input type="checkbox"/> Feet / Inches .25" Div.</p> <p><input type="checkbox"/> 0% to 100%</p> <p><input type="checkbox"/> Metric-Meter/Cm</p> <p><input type="checkbox"/> Other _____</p> <p>Switches:</p> <p><input type="checkbox"/> MGS-200EX _____</p> <p><input type="checkbox"/> MGS-200EX/2 _____</p> <p><input type="checkbox"/> MGS-500EX _____</p> <p><input type="checkbox"/> MGS-700EX _____</p> <p><input type="checkbox"/> MGS-700EX/2 _____</p> <p><input type="checkbox"/> MGS-900EX _____</p> <p><input type="checkbox"/> MGS-900EX/2 _____</p> <p><input type="checkbox"/> MGS-100 _____</p> <p>Transmitters:</p> <p><input type="checkbox"/> MT2523 HART Magnetostrictive</p>	<p align="center">Sketch</p> <p>_____</p> <p>_____</p> <p>_____</p> <p>_____</p> <p>_____</p> <p align="center">Notes/Options</p> <p>_____</p> <p>_____</p> <p>_____</p> <p>_____</p> <p>_____</p>
--	---	--

Part Number: _____

Date Required: _____

Tag Number: _____

Contact: _____

Phone/Fax: _____

E-mail: _____

Quantity: _____

Company: _____

Representative: _____ **Sales Engineer:** _____

888 Clear Creek Ave. League City, Texas 77573

Phone Number:(281) 332-MAG1(6241) Fax Number: (281) 332-0232

www.mag-gage.com